

DEW POINT SENSOR (-100 ... +20 °C Td)

S230 / S231

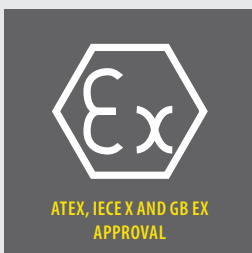

Unique dual sensor system — Outstanding accuracy and wide range



S230 / S231 FEATURES



**ATEX, IECEx
AND GB EX
APPROVAL**



**PRECISE
MEASUREMENT**
Unique QCM
sensor technology



**LOW
DEW POINT**
Measures
down
to -100 °C Td



**DUAL SENSOR
SYSTEM**
High precision
over the whole
range

The SUTO S230 / S231 dew point sensors provide reliable, long term stable dew point monitoring in industrial or hazardous applications. SUTO's unique dual sensor technology optimizes sensor sensitivity and accuracy by automatically selecting the ideal sensor type for the situation.

The S230 / S231 comes ready to use and simple to install with your choice of 4-20mA or Modbus/RTU (RS485) outputs. If required, parameters can quickly and easily be configured through the SUTO service software.

S230 / S231 BENEFITS

- Dew point sensor with optional ATEX, IECEx approval
- Dual sensor technology for high accuracy of 2 °C Td over the whole range from -100 ... +20 °C Td
- Two outputs available: 4 ... 20 mA, RS-485 (Modbus/RTU).
- IP65 casing provides robust protection in rough industrial environment
- G1/2" Process connection

S230 / S231 DIMENSIONS

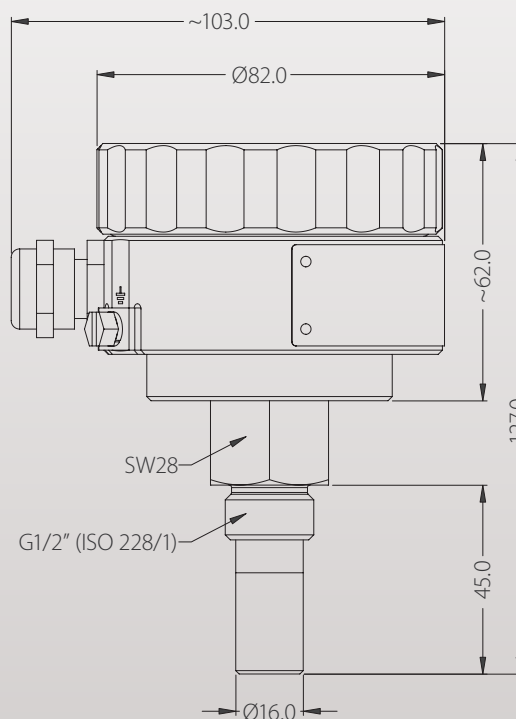

S230 / S231 TECHNICAL DATA

General Specifications		
Measurement range (model depending)	Dew point	-100 ... +20 °C Td (S230) -50 ... +20 °C Td (S231)
	Temperature	-30 ... +70 °C
	Dew point sensor	QCM & Polymer
Temperature sensor	NTC	
Pressure sensor	N/A	
Accuracy	Dew point	±2 °C Td
	Temperature	0.3 °C
Operating Pressure (model depending)	-0.1 ... 1.6 MPa (S230)	
	-0.1 ... 35 MPa (S231)	
Operating Temperature (Medium)	0 ... +50 °C	
Measured gases (Medium)	Non-corrosive gases	
Response Time t90 (@ 4 l/min)	-20 °C Td -> -60 °C Td = < 240 sec	
	-60 °C Td -> -20 °C Td = < 30 sec	
Ambient Temperature	0 ... +50 °C	
Ambient Humidity	0 ... 100% rH	
Supply Voltage	12 ... 30 VDC	
Current consumption	40 mA @ 24 VDC	
Output signals	4 ... 20 mA (isolated)	
	Modbus/RTU	
Electrical connection	Screw terminals	
Process connection	G 1/2" thread (ISO 228/1)	
	Stainless steel 1.4301 (SUS 304)	
Casing material	Aluminum alloy	
Classification	IP67	
EMC	IEC 61326-1	
Approval	Ex db[ib] IIC T4 Gb	
Sensor protection	Sinter filter	
Transport Temperature	-30 ... +70 °C	
Storage Temperature	-20 ... +50 °C	
Weight	728 g	

Stated accuracy under following conditions:

- Ambient temperature 23 °C ±3 °C
- Process temperature 23 °C ±3 °C
- Ambient humidity < 95%, no condensation
- Airflow > 2 l/min at sensor tip

Cable connection



Screw terminals with signal labels inside the connection chamber

Accessories



Measuring chamber with inlet / outlet valve and compression fitting for gas supply

S230 / S231 ORDERING

Please use the following tables to assist in placing your order with our sales staff.



Visit our website or e-mail us:
www.suto-itec.com
sales@suto-itec.com

S230 DEW POINT SENSOR (-100 ... +20 °C Td)	
Order No.	Description
S699 0230	Dew point sensor, -100 ... +20 °C Td, G 1/2" thread, 1.6 MPa, 1 x 4 ... 20 mA, RS-485 (Modbus)
A1480	Ex option ATEX (to be ordered for hazardous environment)
A1481	Ex option IECEx (to be ordered for hazardous environment)
A1482	Ex option GB3836 (to be ordered for hazardous environment)
Accessories	
A554 2301	Measuring chamber with inlet / outlet valve and compression fittings for gas supply, 1.6 MPa
A554 2302	Measuring chamber with insertion type sampling tubes (for applications where purge losses are not acceptable), 1.6 MPa

S231 DEW POINT SENSOR (-50 ... +20 °C Td)	
Order No.	Description
S699 0231	Dew point sensor, -50 ... +20 °C Td, G 1/2" thread, 35 MPa, 1 x 4 ... 20 mA, RS-485 (Modbus)
A1480	Ex option ATEX (to be ordered for hazardous environment)
A1481	Ex option IECEx (to be ordered for hazardous environment)
A1482	Ex option GB3836 (to be ordered for hazardous environment)
Accessories	
A554 2301	Measuring chamber with inlet / outlet valve and compression fittings for gas supply, 1.6 MPa
A554 2302	Measuring chamber with insertion type sampling tubes (for applications where purge losses are not acceptable), 1.6 MPa